



Revised Date: Jan. 16, 2007

## QRZ-3000A ZigBee Transceiver

### Description

The QRZ-3000A is a miniature 2.4 GHz Direct Sequence Spread Spectrum ZigBee transceiver. It includes all RF hardware and a micro-controller to manage the communications link. The micro-controller manages all communications task including configuration, data packaging, and clear channel selection. The result is a complete wireless data communications solution.

The QRZ-3000A package is unique because of its small form factor ( $45 \times 28 \text{ mm}^2$ ), It has an on-board chip antenna and the availability of external dipole antenna SMA connector. No competitive products can offer a solution as flexible, convenient, and easy to integrate,

There are four QRZ-3000 models; the QRZ-3000 with the on-board chip antenna and dipole antenna SMA connector, the QRZ-3000-PA with power amplifier, low noise amplifier, on-board chip antenna and dipole antenna SMA connector. The power amplifier enhances the transmission power and low noise amplifier increase receiving signal sensitivity. The power amplifier, low noise amplifier and dipole antenna improve range while the QRZ-3000 lowers system cost and simplifies integration. Development Kits are available for each version. Two pin-compatible variants are also available, the QRZ-3000A and QRZ-3000A-PA, for applications with pre-loaded transceiver program requirements. The QRZ-3000A is same hardware as QRZ-3000 with pre-loaded transceiver program. The QRZ-3000A-PA is same hardware as QRZ-3000-PA with pre-loaded transceiver program.

### Models

- QRZ-3000: Includes on-board chip antenna and Dipole Antenna Connector
- QRZ-3000-PA: Includes Power Amplifier, Low Noise Amplifier and Dipole Antenna Connector
- QRZ-3000A: Transceiver program pre-loaded QRZ-3000
- QRZ-3000A-PA: Transceiver program pre-loaded QRZ-3000A
- QRZ-2200K: 2 nodes Development Kit
- QRZ-2400K: 4 nodes Development Kit

### Features

- $45 \times 28 \text{ mm}^2$  PCBA package with 2 connectors
- Utilizes globally available 2.4 GHz ISM band
- 65535 unique node addresses, IDs allow multiple large networks to coexist.
- Programmable Transmit Power Output, max. 1 mW
- Complete IEEE 802.15.4 spec compliant



- Typical Receiver Sensitivity –95 dBm
- Typical Throughput rate 250,000 bps
- Non-obstructed signal range to 100 meters
- Multiple Low Power Operating modes

### QRZ-3000A ZigBee Transceiver Module



### QRZ-3000A MECHANICAL SPECIFICATIONS

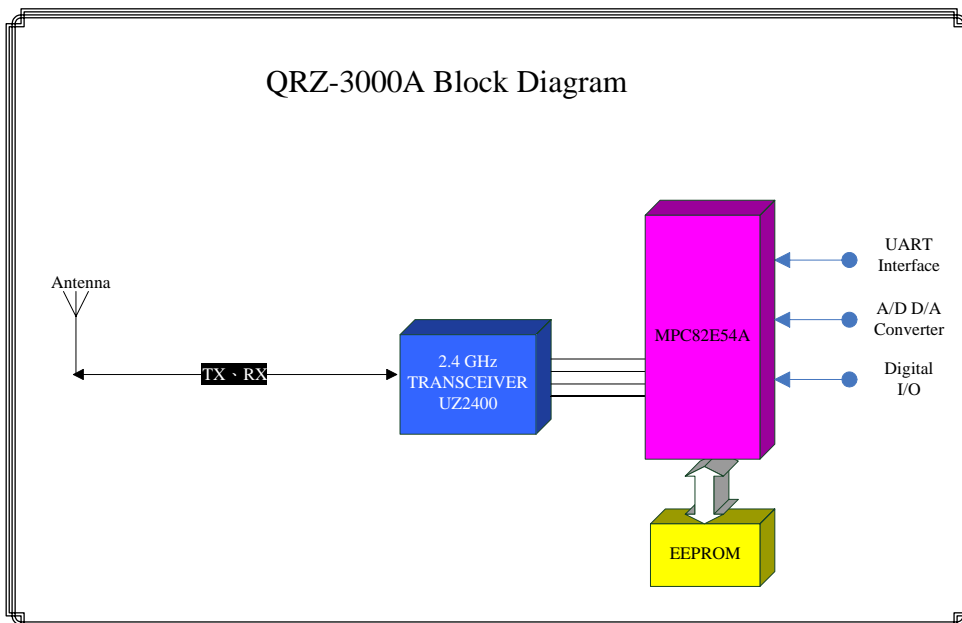

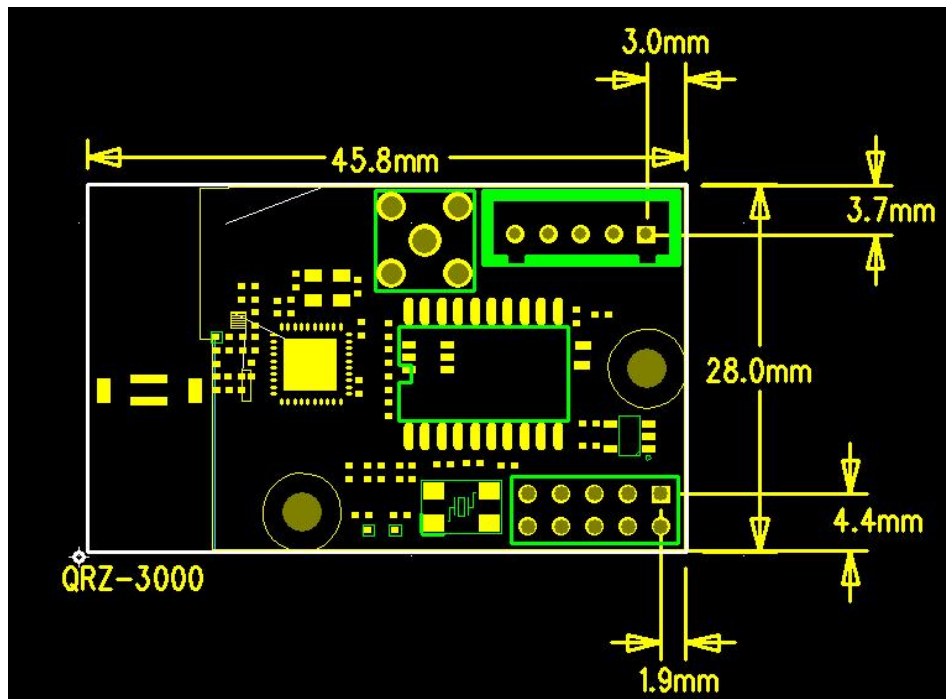

Note : The thickness of PCB board (including PCB and components) is 3.632 mm

### Using the QRZ-3000A Power Saving Modes

The QRZ-3000A includes several low power operating modes to permit the most efficient use of the available power. Below are descriptions of the available selections.

**ACTIVE:** In Active Mode, all QRZ-3000A circuits are powered and available for immediate action. This includes the RF receiver which actively monitors the air for an incoming communications request. Two sub-modes are classified as TX-ACTIVE and RX-ACTIVE. The current consumption of TX-ACTIVE is 22 mA while RX-ACTIVE is 18 mA.

**IDLE:** In Idle mode, all QRZ-3000A RF circuits are shut down but the communications controller remains active to accept AT commands. The QRZ-3000A cannot respond to incoming RF communications requests in Power-Down mode. If a transmit RF or receive RF command is received, The QRZ-3000A can activate the RF section in under 200 microseconds. Current draw in Idle Mode is less than 7.5 milliamps.

**STANDBY:** In Standby mode, all QRZ-3000A RF, MAC and Base Band circuits are powered-down with sleep clock remains active to minimize power consumption. The QRZ-3000A cannot accept commands or respond to incoming RF communications requests from Standby mode. Any input on TXD awakens the transceiver. Current draw in Standby Mode is less than 3.5 uA.



**DEEP SLEEP:** In Deep Sleep Mode, all QRZ-3000A circuits are shutdown except digital-side power. Current draw in Deep Sleep Mode is only 2 uA.

**WAKE-UP:** QRZ-3000A has two wake-up modes: timed wake-up and immediate wake-up. Timed wake-up has two sub-modes: beacon and non-beacon modes. However, if programmer sets both “main counter” and “remain counter” zero, QRZ-3000A will not wake up without immediate wake-up. QRZ-3000A can be wakened up externally. It can also be wakened up by setting internal register.

### QRZ-3000A CONNECTORS PIN CONFIGURATION

QRZ-3000A uses Megawin MPC82E54A as MCU. It is an 8051 base MCU and reserves 10 GPIO pins for external controlling by application. Each pin can be a general I/O pin and programmed it by user directly. Furthermore, most of these pins can be used as special purpose function. Thereof TX, RX pins can be programmed as UART for data communication. For example, user is easy to connect these pins with RS485 transceivers such as 75176, MAX485, or programs to a 10-bit ADC, or PCA.

QRZ-3000A ZigBee transceiver provides J1, J2 two connectors for application usage. The J1 connector circuit and pin configuration show as below in which VDD and GND are used for power supply. The TX and RX are used for UART transmitting and receiving data. But TX and RX are used in pair. That means you can't use TX or RX only and use another pin as GPIO. The pin 3 is a MCU GPIO pin and defined as port 1.3. In programming stage, TX, VDD and GND of J1 are also defined as Megawin ISP programming interface for downloading the program

#### Connector J1 Pin Configuration

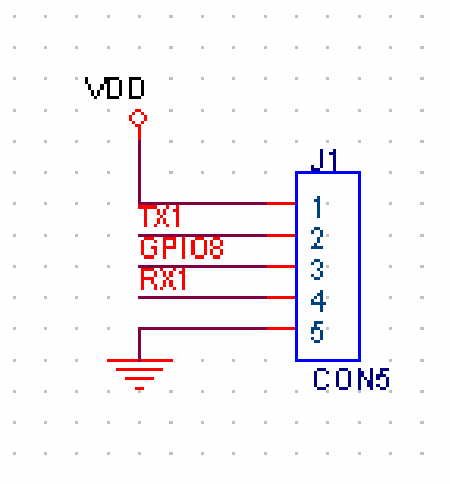

**Connector J1 Pin Configuration**

Signal	Pin	Description
VDD	1	3.3 Volt power for the QRZ-3000A
TX	2	GPIO, also used as UART TX, transmit Data is the data input to the QRZ-3000A
RX	3	GPIO, also used as UART RX, received Data is the data output from the QRZ-3000A.
P1.3	4	GPIO8, also used as ADC3, this pin is same pin as J2 pin 10
GND	5	Common voltage reference for the QRZ-3000A

The J2 connector circuit and the pin configuration show as below in which VDD and GND are used for power supply. The pin 3 to P10 are MCU GPIO pins and defined as port 1.0~port 1.3, port3.3~port3.5, port3.7 respectively. These GPIO pins can interface with other devices such as sensor, LED, host controller, push button, joystick or power relays through a 5x2 connector. All of these GPIO pins can be programmed as other functions such as external interrupt, 10-bit ADC (3 sets), timer (16-bit), PGA(Programmable Counter Array) etc. The detail function definitions have showed as below.

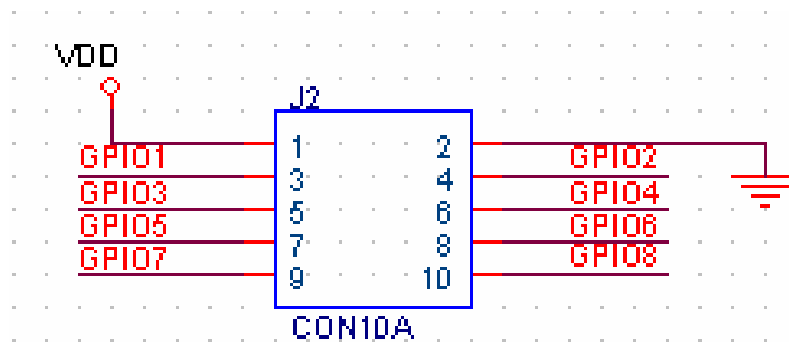
**Connector J2 Pin Configuration****Connector J2 Pin Configuration**

Signal	Pin	Description
VDD	1	3.3 Volt power for the QRZ-3000A
GND	2	Common voltage reference for the QRZ-3000A
GPIO1	3	GPIO port 3.3, may be programmed as either a digital input or digital output. It also can be programmed as external interrupt
GPIO2	4	GPIO port 3.4, may be programmed as either a digital input or digital output. It also can be programmed as external clock input to PCA as



		alternative clock input to timer-0
GPIO3	5	GPIO port 3.5, may be programmed as either a digital input or digital output. It also can be programmed as external clock input to PCA as alternative clock input to timer-1
GPIO4	6	GPIO port 3.7, may be programmed as either a digital input or digital output. It also can be programmed as external clock input to PCA
GPIO5	7	GPIO port 1.0, may be programmed as either a digital input or digital output. It also can be programmed as analog to digital converter (ADC0)
GPIO6	8	GPIO port 1.1, may be programmed as either a digital input or digital output. It also can be programmed as analog to digital converter (ADC1)
GPIO7	9	GPIO port 1.2, may be programmed as either a digital input or digital output. It also can be programmed as analog to digital converter (ADC2)
GPIO8	10	GPIO port 1.3, may be programmed as either a digital input or digital output. It also can be programmed as analog to digital converter (ADC3)

#### Absolute Maximum Rating

VCC	3.6V
Storage temperature	-40°C to +120°C
Operating temperature Range	-30°C to +80°C

WARNING: Exceeding any of these ratings will void the warranty and may damage the device

#### QRZ-3000A ELECTRICAL SPECIFICATIONS

Parameters	Min	Typ	Max	Units
Supply Voltage for RF, analog and digital circuits	2.4		3.6	V
Supply Voltage for Digital I/O	2.4	3.3	3.6	V
Current Consumption				
ACTIVE TX Mode @ 0 dBm		22		mA
ACTIVE RX Mode		18		mA
IDLE Mode		7.5		mA
STANDBY Mode		3.5		uA
DEEP SLEEP Mode		2		uA
Output Power		1		mW
Wireless Receive Sensitivity		-95		dBm
Range thru no Physical Obstructions @ 0 dBm		100		meter
Selectable Channels		16		channel



Frequency Band	2.400		2.4835	GHz
Antenna Output Impedance		50		Ohms

**QRZ-3000A CIRCUIT DIAGRAM**

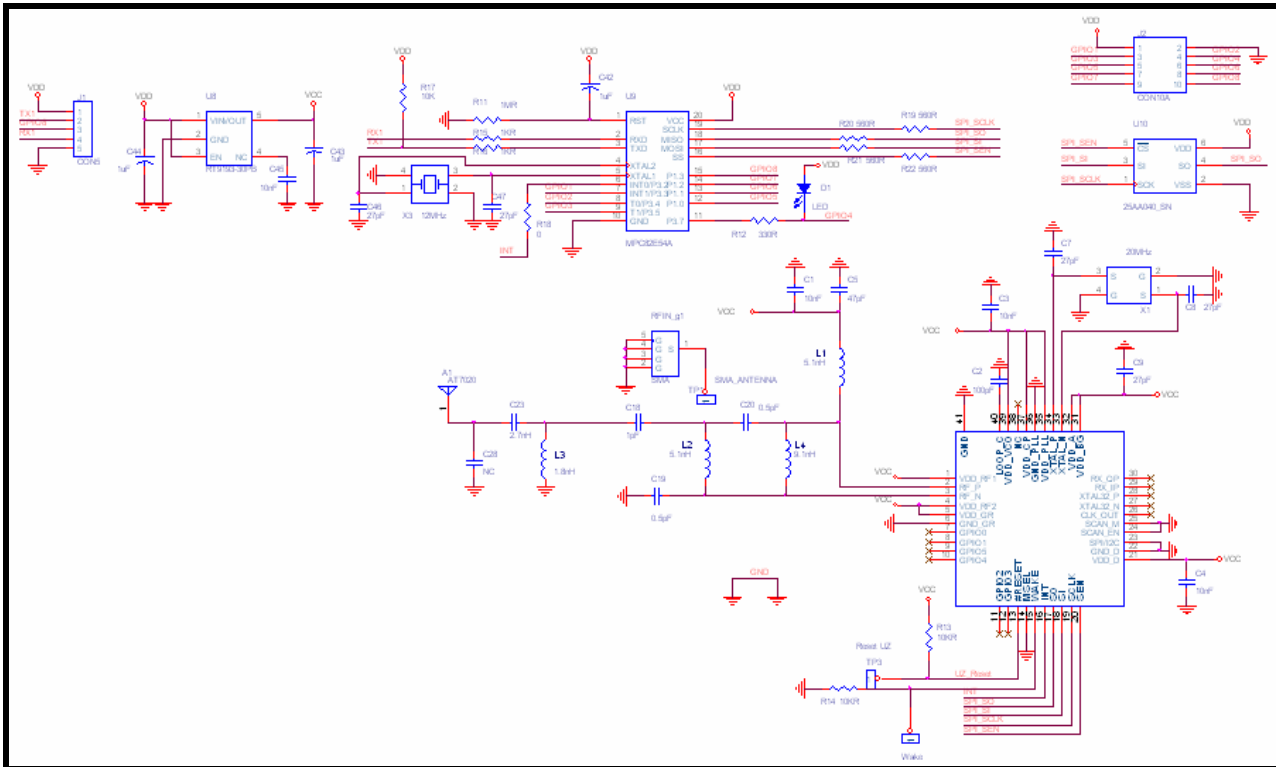

**PART LIST OF QRZ-3000A CIRCUIT DIAGRAM**

Item	Quantity	Reference	Part	Description
1	1	A1	AT7020	AT7020
2	3	C1,C4,C45	10nF	0402
3	1	C2	100pF	0402
4	1	C3	10nF	0402
5	1	C5	47pF	0402
6	2	C7,C8	27pF	0402
7	3	C9,C46,C47	27pF	0402
8	1	C18	1pF	0402
9	2	C20,C19	0.5pF	0402
10	1	C23	2.7nH	0402
11	1	C28	NC	NC/2
12	3	C42,C43,C44	1uF	0402
13	1	D1	LED	0805



14	1	J1	CON5	WAFER-A2501WV-5P
15	1	J2	CON10A	HD5X2_2.54
16	2	L2,L1	5.1nH	0402
17	1	L3	1.8nH	0402
18	1	L4	9.1nH	0402
19	1	RFIN_g1	SMA	SMA-1023-1-TGG
20	1	R11	1MR	0402
21	1	R12	330R	0402
22	2	R14,R13	10KR	0402
23	2	R15,R16	1KR	0402
24	1	R17	10K	0402
25	1	R18	0R	0402
26	4	R19,R20,R21,R22	560R	0402
27	1	TP1	SMA_ANTENNA	TP24S
28	1	TP2	Wake	TP24S
29	1	TP3	Reset UZ	TP24S
30	1	U1	UZ2400	UZ2400
31	1	U8	RT9193-30PB	SOT-23-5
32	1	U9	MPC82E54A	SOP20-7.5_1.27
33	1	U10	25AA040_SN	SOT-23-6
34	1	X1	20MHz	CX_101F
35	1	X3	12MHz	XTAL-5X3.2-4P_S



**QRZ-3000A AT COMMANDS****QRZ-3000A AT Command Format**

Each command follows a standard command format as described below. Commands are accepted at data rates from 1200 to 115,200 bps. The default serial data rate is 9600 bps

**Header** --- Each command begins with 0x88000088. The prefix identifies the commands sent to the QRZ-3000A by matching the pattern of command header "0x88000088".

**Command Byte** --- Each commands is only one byte after command header, the detail command definition is described as below.

**Command Length** --- In case of command follow by parameters, the command length will define the parameter length in this byte.

**Command Parameters** --- Command parameters will be added after command length,

**Tail** --- Each command ends with 0xCCFFFFCC. The postfix identifies the commands sent to the QRZ-3000A by matching the pattern of command postfix "0xCCFFFFCC".

The total command packet is no longer than 240 bytes.

Command Format	Data Type	Value	Description
Header	UINT32	0x88000088	Command Header
CMD	UINT8	Define as below	Command Byte
CMD Length	UINT8	variable	Command Length
Parameters	UINT8	variable	Command Parameters
Tail	UINT32	0xCCFFFFCC	Command Tail

**Command Byte Definition**

0x01 : Set Router Parameters

0x02 : Set Router Parameters ACK

0x03 : Get Router Parameters

0x04 : Get Router Parameters ACK

0x05 : Set Device Parameters

0x06 : Set Device Parameters ACK

0x07 : Get Device Parameters

0x08 : Get Device Parameters ACK



0x09 : Set Coordinator Parameters  
0x0A : Set Coordinator Parameters ACK  
0x0B : Get Coordinator Parameters  
0x0C : Get Coordinator Parameters ACK  
0x13 : Get Software Version  
0x14 : Get Software Version ACK  
0x15 : Clear Parameters  
0x16 : Clear Parameters ACK  
0x17 : Set Fixed Parameters  
0x18 : Set Fixed Parameters ACK  
0x19 : Get Fixed Parameters  
0x1A : Get Fixed Parameters ACK  
0x1B : Set Network Configuration  
0x1C : Set Network Configuration ACK  
0x1D : Get Network Configuration  
0x1F : Get Network Configuration ACK  
0x20 : Set Sensor Parameters  
0x21 : Set Sensor Parameters ACK  
0x22 : Get Sensor Parameters  
0x23 : Get Sensor Parameters ACK  
0x40 : Send Data Upload With Address  
0x41 : Send Data Download With Address  
0x42 : Send Data Upload by Broadcast  
0x43 : Send Data Download by Broadcast  
0x60 : Request Router to Set Parameters  
0x61 : Request Device to Set Parameters  
0x62 : Device Send Sensor Data to Coordinator  
0x63 : Device Send Sensor Data ACK  
0x67 : Raw Data Transfer  
0x68 : Get System Status  
0x69 : Get System Status ACK  
0x6A : System Re-Start  
0x6B : Check Connection Status



RF PERFORMANCE TEST DATA

Return Loss: -22.5dB

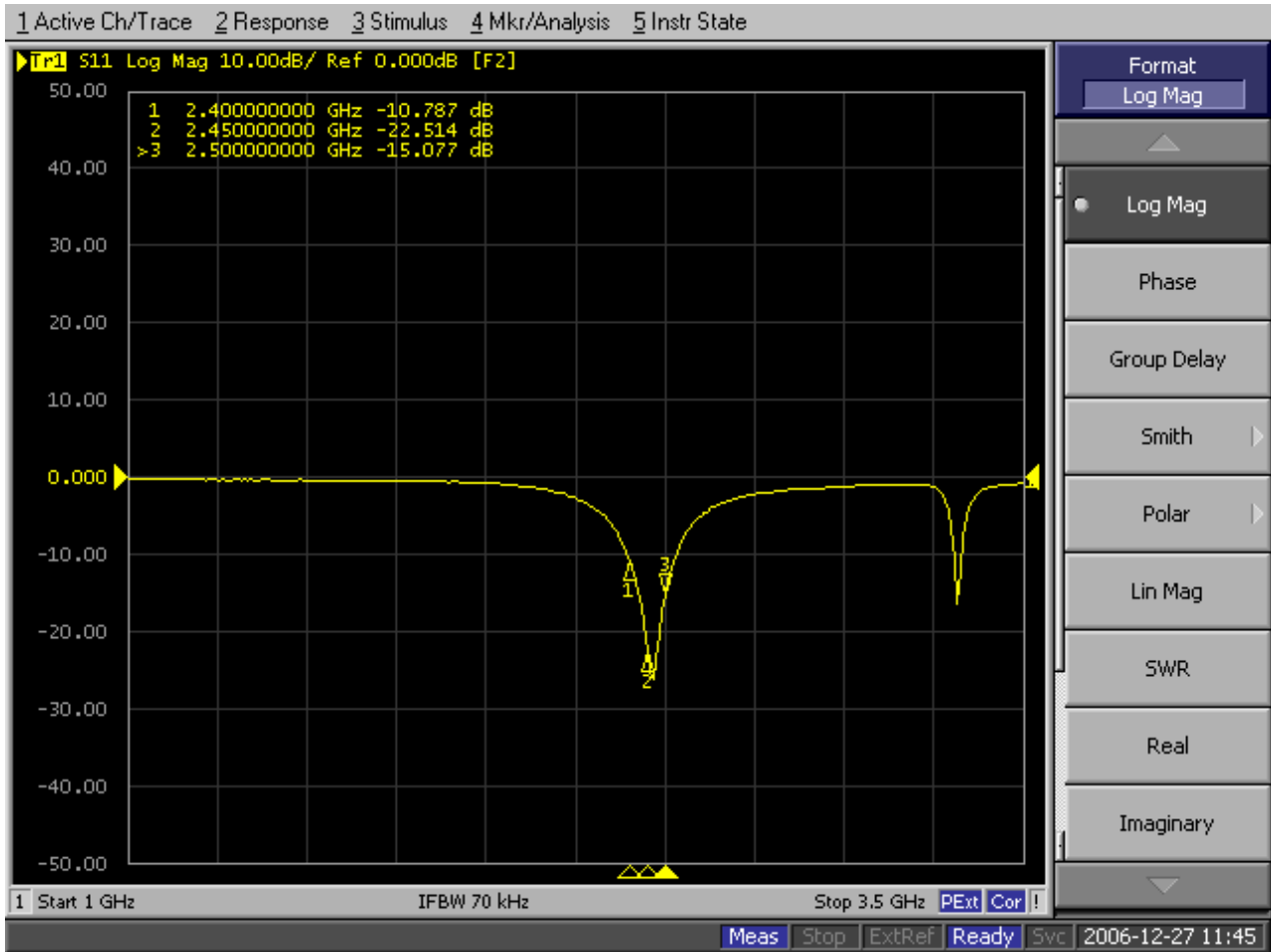

Copyright, QuadRep Electronics © 2007

While QuadRep Electronics, Inc. has made every effort to ensure that the information presented here is accurate, QuadRep will not be liable for any damages arising from errors or omission of fact. QuadRep reserves the right to modify specifications and/or prices without notice. Products mentioned herein are used for identification purposes only and may be trademarks and/or registered trademarks of their respective companies.



**QuadRep Electronics [T] Ltd.**

5F-13, No. 79, Hsin Tai Wu Rd, Sec.1, His-Chih, Taipei, Taiwan

TEL: +886-2-26989933

FAX: +886-2-26989911

http:// [www.quadrep.com.tw](http://www.quadrep.com.tw)

http:// [www.quadrep.com.cn](http://www.quadrep.com.cn)